



EXHIBIT/BOOTH SPECIFICATIONS

BOOTHS

ALL BOOTHS 10' WIDE X 10' DEEP UNLESS OTHERWISE NOTED.

AISLES

ALL AISLES 10' WIDE. MAIN AISLES 15' – 20' WIDE.

CEILING HEIGHTS

NORTH HALL

AISLES N100-N1700 33'*

AISLES N1800-N3200 35'*

CENTRAL HALL

AISLES C4000-C4600 25'**

AISLES C4800 31'***

AISLES C5100-C7800 35'

AISLES C3400-C3900 25'

SOUTH HALL, LEVEL 1

AISLES S10000-S12200 25'

AISLE S12300 (EVEN NUMBERED BOOTHS) 25'

AISLE S12300 (ODD NUMBERED BOOTHS) 30'

AISLES S12400-S15100 30'

***THE NORTH HALL HAS LOWER CEILING HEIGHTS IN SEVERAL AREAS; SEE FLOOR PLAN FOR SPECIFICS.**

****PORTIONS OF BOOTHS IN THE C4600 AISLE HAVE A CEILING HEIGHT OF 21'6".**

*****PORTIONS OF BOOTHS C4881 AND C4981 HAVE A CEILING HEIGHT OF 15'.**

UTILITIES

ELECTRICITY, GAS, COMPRESSED AIR, WATER AND TELEPHONES ARE AVAILABLE. ALL UTILITIES COME FROM OVERHEAD AT THE LAS VEGAS CONVENTION CENTER, EXCEPT IN THE SOUTH HALL, ELECTRICITY AND TELEPHONE SERVICES COME FROM THE COLUMNS.

FLOORLOAD

UNLIMITED NORTH HALL, CENTRAL HALL *, SOUTH HALL, LEVEL 1

*EXCEPT FOR AISLES C4800-C4900, WHICH HAVE A 175 LBS/SQ FT MAXIMUM WEIGHT LOAD



EXHIBIT/BOOTH SPECIFICATIONS

BOOTH SPECIFICATIONS

PLEASE REVIEW THE FOLLOWING BOOTH SPECIFICATIONS TO ENSURE THAT YOUR DISPLAY MEETS THE EXHIBIT/BOOTH GUIDELINES. ALL BOOTHS, REGARDLESS OF SIZE, ARE REQUIRED TO FOLLOW THESE GUIDELINES. FOR QUESTIONS REGARDING BOOTH SPECIFICATIONS, PLEASE CONTACT SHOW MANAGEMENT AT 866-962-7469 OR OPERATIONS@WORLDOFCONCRETE.COM.

BOOTH EQUIPMENT

Standard 10' x 10' Linear Booths will be set with 8' 3" high black back drape and 3' high black side drape. All booths **MUST** have a professionally finished floor covering.

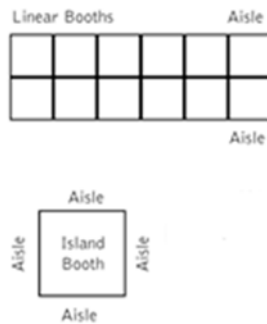

LINEAR (IN-LINE) BOOTHS

Definition: Linear Booths have at least one side exposed to an aisle and have at least one adjacent neighbor on either side of the booth.

Booths are typically 10' wide and 10' deep. In the back 5' section, display material, signage, equipment and product may not exceed 12' in overall height. Any display material, signage, equipment and product over 8' 3" must be professionally finished or draped on the back. Show Management will determine what is considered professionally finished. Exhibitor may be required to order drape to cover unapproved back wall. Signs, banners, logos, images, symbols or flags (including those manufactured on the product or equipment) are not permitted on the backside of the back wall or sidewall at any height. In the front 5' section, equipment, product, display material and signage may not exceed 4' in overall height. Please reference the diagram of allowable configurations. *No signs or truss work hung from the ceiling are allowed in linear booths.*

Note: When three or more Linear Booths are used as a single exhibit space, the 4' height limitation in the front of the booth is applied only to that portion of exhibit space, which is within 10' of an adjoining booth.

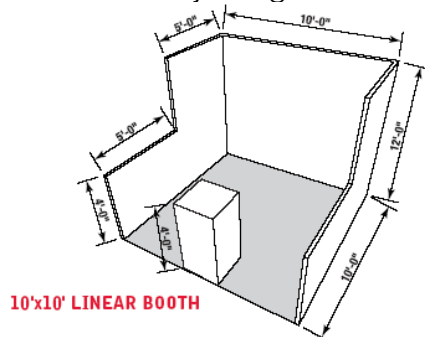

10'x10' LINEAR BOOTH

12' maximum height for display material, signs, back wall and sidewalls, equipment and product; no signage permitted on the back side of the back wall or sidewalls at any height; backside over 8'3" must be professionally finished or draped.

4' maximum height for equipment, product, display material, signs and sidewall

10' X 10' or 10' X 20' BOOTHS

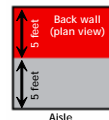

10' X 30' and LARGER BOOTHS

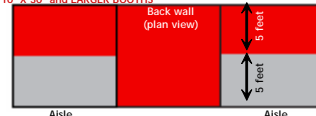

EXHIBIT/BOOTH SPECIFICATIONS

PERIMETER LINEAR BOOTH

Definition: A Perimeter Booth is a Linear Booth that backs to a wall of the facility rather than another exhibit booth.

All guidelines for a Linear Booth apply to a Perimeter Booth except that the maximum back wall and sidewall height allowed in the back 5' section is 16' for display material, signage, equipment and product. This includes signs, banners, logos, images, symbols or flags. *No signs or truss work hung from the ceiling are allowed in perimeter booths.*

10'x10' PERIMETER BOOTH

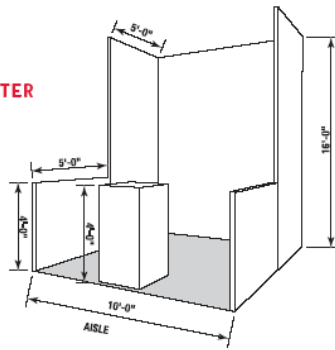



PENINSULA BOOTHS

Definition: Peninsula Booths are exposed to aisles on three (3) sides and are backed by linear booths. Peninsula Booths are 20' wide by 20' deep or greater. The same principles apply regardless of booth size.

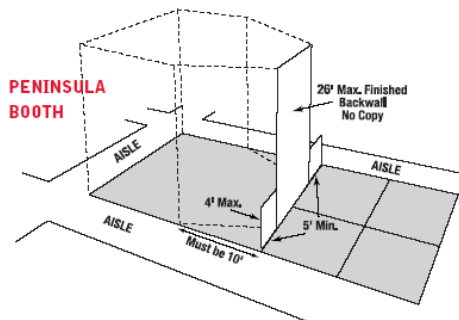
Display material, signage (including hanging signs), sidewalls and back wall will be permitted up to a maximum height of 26' when ceiling height permits; except in the 5' section on each side of the back wall which has a 4' maximum height for equipment, product, display material, signs, sidewall and back wall. Unlimited height for equipment and product is permitted throughout the allowable booth space. Please reference the diagram of allowable configurations. No signage (including hanging signs) is permitted on the backside of the back wall at any height. Hanging signs must be placed at least 5' from the back wall.



 Unlimited height for equipment and product; 26-ft. maximum height for display material, signs, back wall and sidewall (when ceiling height permits); no signage (including hanging signs) permitted on the backside of the back wall at any height; hanging signs must be at least 5' from the back wall

 4-ft. maximum height for equipment, product, display material, signs, back wall and sidewall

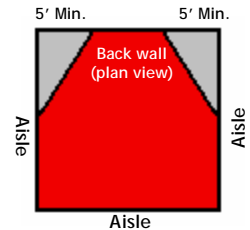



EXHIBIT/BOOTH SPECIFICATIONS

ISLAND BOOTHS

Definition: An Island Booth is any 20' wide by 20' deep or greater booth exposed to aisles on all four sides of the booth.

Display material and signage (including hanging signs) will be permitted up to a maximum height of 26' when ceiling height permits. Unlimited height for equipment and product is permitted throughout the booth.

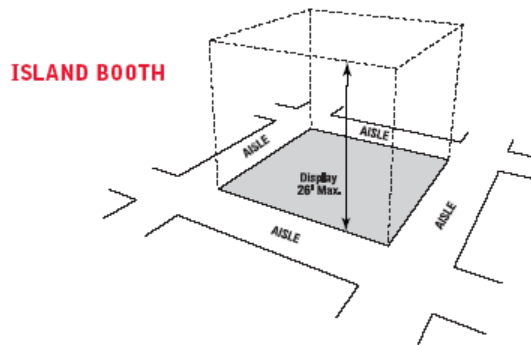



EXHIBIT/BOOTH SPECIFICATIONS

HANGING SIGNS

Hanging signs are defined as banners, logos, images, symbols and flags.

Hanging signs and truss work hung from the ceiling are not permitted in linear and perimeter booths.

Hanging signs will be permitted in the following booth configurations to a maximum height (dependent on ceiling height in exhibit hall) of:

- Peninsula Booth: 26' maximum from floor to top of sign
- Island Booth: 26' maximum from floor to top of sign

- ALL hanging signs must be a minimum of 9' off the floor (from the floor to the bottom of the sign).

Signs may be hung from the ceiling (where permitted), truss work or equipment. Signs that will be hung from the ceiling or truss work must be installed and dismantled by Freeman.

HANGING SIGNS FROM EQUIPMENT

Hanging signs from equipment must conform to the height limitations above. Freeman must approve rigging of signs that weigh over 250 pounds and are hung by the exhibitor or Exhibitor Appointed Contractor.

For questions on hanging signs, please call Freeman Decorating at 702-579-1700.

LIGHTING

Lighting (including lasers) must be contained within the confines of the booth and must not wash into aisles or other booths. Strobe lights that are not sold as product by the exhibiting company are prohibited.

Note: Las Vegas Convention Center has specific rules on the use of halogen lights. Please reference the Exhibitor Service Manual for full details.

SOUND/MUSIC

Sound of any kind may not be projected outside the confines of the booth. Show Management reserves the right to determine if sound constitutes interference and must be discontinued.

DEMONSTRATIONS

When conducting demonstrations or presentations, all activity and viewers must be contained within the booth and all aisles must remain clear. To prevent gatherings in an aisle, demonstrations cannot be conducted on any edge of the booth along an aisle.



EXHIBIT/BOOTH SPECIFICATIONS

TENTS, AWNINGS, CANOPIES

Covered or canopied booths require approval by show management. Exhibitors must submit structural approved plans and a Certificate of Insurance with the coverages outlined in Clause 25 of the Exhibitor Contract.

Covered areas will be required to have approved battery-powered smoke detectors which emit alarms audible outside of the enclosed or covered area.

There must be fire extinguishers, minimum class 2A10BC*, in each enclosed area. There shall be a locally approved Fire Watch for enclosures larger than 300 square feet (92.9 sq. m).

All multi-story exhibits and covered/canopied booths are required to submit structural engineered certified plans to Show Management (tyler.johnson@informa.com) and the LVCC (boothplans@lvcva.com) for approval. A Certificate of Insurance with the coverages outlined under Clause 25 of the Exhibitor Contract should also be included. Written requests must be submitted at least two months prior to move-in and must include detailed plans showing size, height, location, anchoring detail, and certification of flame retardant for all materials.

Exhibitors using canopies or false ceilings over their exhibit may use vertical supports up to 3 inches in width in the corners of their space. Vertical supports that are strictly decorative will not be permitted.